



NPV20PD



# PLATFORM POWER



Kawasan Industri MM2100, Jl. Selayar, Mekarwangi, Kec. Cikarang Barat,  
Kabupaten Bekasi, Jawa Barat 17530

+6285776986689

[mala@satriaselaras.com](mailto:mala@satriaselaras.com)



## CARRY MORE AND WALK LESS

DESIGNED FOR DOUBLE STACKING APPLICATIONS AND FOR TRANSPORTING LOADS OVER MEDIUM AND LONG DISTANCES, THIS DOUBLE PALLET HANDLER SAVES TIME BY HALVING THE REQUIRED NUMBER OF MOVEMENTS. MEANWHILE, THE FOLD-DOWN OR FIXED RIDE-ON PLATFORM REDUCES OPERATOR LEGWORK.



The NPV20PD double pallet handler with foldable platform saves time by carrying two pallets simultaneously (one above the other). It is perfect for double stacking on the loading ramp and for transporting incoming or outgoing loads over short, medium or long distances.



The ergonomic tiller arm helps keep operators fresh with comfortable, easy-to-use controls, while fixed platform options with a variety of barrier and entry/exit designs add extra safety and comfort.

## LOWER COST OF OWNERSHIP

- Sturdy chassis construction and endurance-tested forks provide enhanced robustness and reliability even in the toughest conditions.
- Easy access to critical truck components allows faster fault diagnosis and speedier maintenance, squeezing downtime still further.
- Dust-shielded load wheels help extend life of wheel bearings.

## UNMATCHED PRODUCTIVITY

- AC motor results in very precise drive control, for easier operation.
- Ergonomic tiller arm helps keep operators fresh with comfortable, easy-to-use controls.
- Excellent drive and traction characteristics suit intensive work over medium and long distances.
- Programmable controller lets users prioritise between faster performance and smoother handling with lower energy consumption, prolonging shift life.
- Truck can be driven with tiller arm in vertical position in ultra-low-speed mode to maximise manoeuvrability.
- Folding platform stays down, saving time when operators go to remount.
- Narrower truck body makes loading/unloading in confined areas like goods vehicle trailers much easier.
- Double pallet handling capability halves the number of movements required.

## SAFETY AND ERGONOMICS

- Low step height for mounting/dismounting without effort.
- Strong folding sidebars protect and support operators at all times (optional).
- Large lift/lower buttons allow easy one-handed control even with gloves.
- Five-point chassis with hydraulic friction force system and anti-rollback functionality enhances ergonomics and safety.
- Fixed platform options with a variety of barrier and entry/exit designs add extra safety and comfort.



# STANDARD EQUIPMENT AND OPTIONS

GENERAL	
Micro-computer incl. hour meter and battery indicator with cutout (ATC T4)	●
PIN code login 100 codes	●
Foldable platform	●
Foldable sidebars	○
Short tiller arm with display and keypad	●
Chill store design, down to 1°C, with rust-protected axles	●
Speed regulated lift motor	●
Proportional valve for lowering, controlled by rocker switch on tiller head	●
Polyurethane wheels	●
Initial lift	●
Tandem load wheels Polyurethane	●
Single load wheel	○
Battery rollers	●
Li-ion batteries	○
ENVIRONMENT	
Cold store design, 0C° to -35C°	○
DRIVE AND LIFT CONTROLS	
Heavy duty tiller head - with key switch entry	○
Tiller arm - adjustable in length	○
Tiller up drive	○

NPV20PD

WHEEL OPTIONS	
Polyurethane traction and load wheels	●
Power friction traction wheel	○
Non-marking drive wheel	○
Anti-static drive wheel	○
Pallet entry/exit rollers	○
OTHER OPTIONS	
Driver protected platform rear entry	○
Driver protected platform side entry	○
Power steering	○
Warm environment fan	○
Overhead guard	○
Load backrest low or high	○
Key switch entry	○
12V DC power socket	○
Equipment bar	○
Writing desk incl. RAM C holder	○
Equipment bar holder RAM system size C	○
Equipment bar holder RAM system size C, 2 pcs	○
Equipment bar holder RAM size D	○
Increased drive speed with/without load 10/12.5 km/h	○
Prepared for frequent battery changeover, (BCO)	○
Special RAL colour	○

NPV20PD

● Standard    ○ Option



Kawasan Industri MM2100, Jl. Selayar, Mekarwangi, Kec. Cikarang Barat,  
Kabupaten Bekasi, Jawa Barat 17530  
+6285776986689  
mala@satriaselasar.com

Characteristics			
1.1	Manufacturer		Cat Lift Trucks
1.2	Manufacturer's model designation		<b>NPV20PD</b>
1.3	Power source		Battery
1.4	Operator type		Pedestrian/stand-on
1.5	Load capacity	Q (kg)	2000 / 1000 + 1000
1.6	Load centre distance	c (mm)	600
1.8	Load wheel axle to fork face (forks lowered)	x (mm)	982/832
1.9	Wheelbase	y (mm)	1754 / 1604
<b>2.0 Weight</b>			
2.1	Truck weight without load, with maximum battery weight	kg	1270
2.2	Axle loadings with nominal load & maximum battery weight, drive / load side	kg	1230 / 2040
2.3	Axle loadings without load & with maximum battery weight, drive / load side	kg	940 / 330
<b>3.0 Wheels, Drive Train</b>			
3.1	Tyres: PT = Power Thane, Vul = Vulkollan, P = Polyurethane, N = Nylon, R = Rubber drive / load side		Vul / Vul
3.2	Tyre dimensions, drive side	(mm)	230 x 90
3.3	Tyre dimensions, load side	(mm)	85 x 70
3.4	Castor wheel dimensions (diameter x width)	(mm)	150 x 60
3.5	Number of wheels, load / drive side (x = driven)		1 x + 2 / 4(2)
3.6	Track width (centre of tyres), drive side	b10 (mm)	526
3.7	Track width (centre of tyres), load side	b11 (mm)	390
<b>4.0 Dimensions</b>			
4.2	Height with mast lowered	h1 (mm)	1410 / 1560
4.4	Lift height	h3 (mm)	1585 / 2000
4.5	Height with mast extended	h4 (mm)	2095 / 2395
4.6	Initial lift	h5 (mm)	120
4.7	Height to top of overhead guard	h6 (mm)	2287
4.8	Seat or stand height	h7 (mm)	165
4.9	Height of tiller arm / steering console (min/max)	h14 (mm)	1135/1475
4.10	Height of support legs	h8 (mm)	87
4.15	Fork height, fully lowered	h13 (mm)	90
4.19	Overall length	l1 (mm)	2185 / 2571
4.20	Length to fork face	l2 (mm)	1035
4.21	Overall width	b1/b2 (mm)	770
4.22	Fork dimensions (thickness, width, length)	s / e / l (mm)	65/180/1150,1000
4.24	Fork carriage width	b3 (mm)	590
4.25	Outside width over forks (minimum / maximum)	b5 (mm)	570
4.32	Ground clearance at centre of wheelbase, (forks lowered)	m2 (mm)	17
4.33c	Working aisle width (Ast) with 1000 x 1200 mm pallets, load crosswise, platform up/down	Ast (mm)	2685 / 3072
4.34c	Working aisle width (Ast) with 800 x 1200 mm pallets, load lengthwise, platform up/down	Ast (mm)	2668 / 3055
4.34d	Working aisle width (Ast3) with 800 x 1200 mm pallets, load lengthwise, platform up/down	Ast3 (mm)	2430 / 2817
4.35	Turning radius	Wa (mm)	1030 + x / 1417 + x
<b>5.0 Performance</b>			
5.1	Travel speed, with / without load	km / h	10 / 10 (12.5)
5.2	Lifting speed, with / without load	m / s	0.20 / 0.32
5.3	Lowering speed, with / without load	m / s	0.39 / 0.24
5.7	Gradeability, with / without load	%	6.5 / 17.2
5.8	Maximum gradeability with / without load	%	14.5 / 27.7
5.9	Acceleration time (10 metres) with / without load	s	6.1 / 4.9
5.10	Service brakes (mechanical / hydraulic / electric / pneumatic)		Electric
<b>6.0 Electric motors</b>			
6.1	Drive motor capacity (60 min. short duty)	kW	2.2
6.2	Lift motor output at 15% duty factor	kW	3.2
6.4	Battery voltage/capacity at 5-hour discharge	V / Ah	24 / 220 - 400
6.5	Battery weight	kg	250 - 370
<b>8.0 Miscellaneous</b>			
8.1	Type of drive control		Stepless
10.7	Level of noise at the ear level of the driver according to EN 12 053:2001 and EN ISO 4871 in work LpAZ	dB (A)	60.1

**NPV20PD**

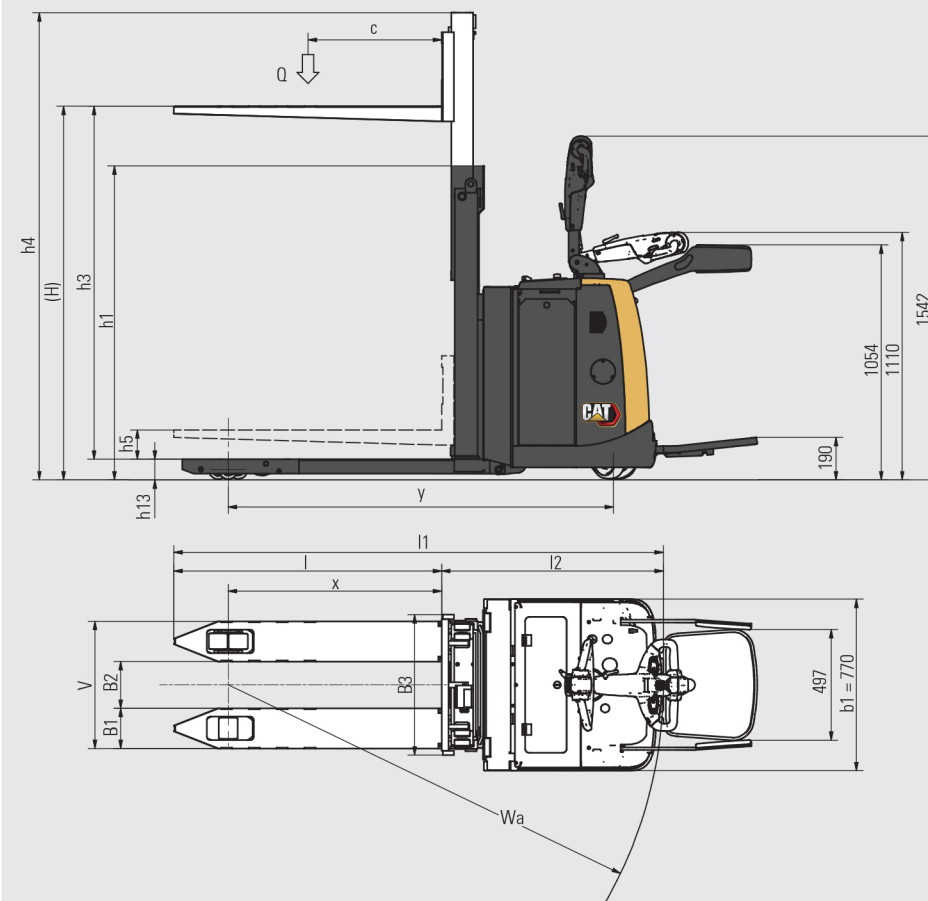

- h1 Height with mast lowered
- h2 Standard free lift
- h3 Lift height
- h13 Fork height, fully lowered

NPV20PD			
Mast Type	h3+h13	h1*	h2+h13
	mm	mm	mm
Duplex	1675	1410	NA
Without Free Lift (DS)	2090	1560	NA

\* h1 closed mast height includes polycarbonate finger protection. Mast height excl. finger protection is 1343mm / 1493mm

Ast = Wa-x+l6+200  
 Ast = Working aisle width  
 Wa = Turning radius



Kawasan Industri MM2100, Jl. Selayar, Mekarwangi, Kec. Cikarang Barat, Kabupaten Bekasi, Jawa Barat 17530  
 +6285776986689  
 mala@satriaselasaras.com

SALES, SERVICE, PARTS

# CAT® LI-ION BATTERIES

## TIME TO SWITCH?



Lithium-ion (Li-ion) battery technology is now available as an option in almost all Cat® electric counterbalance and warehouse truck ranges. While lead-acid batteries remain a popular choice for our customers, and still have much to offer, they present various challenges which Li-ion can overcome.

Perhaps the most noticeable change when switching to Li-ion is the use of opportunity charging. Instead of exchanging batteries between shifts, you can simply plug into a fast charger during short breaks and keep the same battery going 24/7. This, together with other efficiency, environmental and safety benefits, makes Li-ion a very appealing alternative.

 <b>LONGER LIFE</b>	 <b>HIGHER EFFICIENCY</b>	 <b>LONGER RUNTIME</b>	 <b>CONSISTENT PERFORMANCE</b>
 <b>FASTER CHARGING</b>	 <b>NO BATTERY CHANGING</b>	 <b>NO DAILY MAINTENANCE</b>	 <b>INBUILT PROTECTION</b>

### Cat Li-ion advantages over lead-acid

Switching to Li-ion requires a higher initial investment, but this should be viewed against Li-ion's ongoing savings on energy, equipment, labour and downtime.

- **Longer life** – 3 to 4 times lead-acid lifespan – reduces overall battery investment
- **Higher efficiency** – energy losses during charging and discharging are up to 30% lower, so electricity consumption is reduced
- **Longer runtime** – thanks to more efficient battery performance and use of opportunity charges, which can be given at any time without damaging the battery or shortening its lifespan
- **Consistently high performance** – with a more constant voltage curve – maintains greater truck productivity, even toward the end of a shift
- **Faster charging** – enables full charge in as little as 1 hour with the fastest chargers
- **No battery changing** – fast opportunity charges – 15 minutes for several hours of extra runtime – enable continuous operation with just one battery and minimise the need to buy, store and maintain spares
- **No daily maintenance** – the battery stays on board the truck for charging and there is no need for water top-ups or electrolyte checks
- **No gas** – or acid spills – avoids the space, equipment and running costs of a battery room and ventilation system
- **Inbuilt protection** – intelligent battery management system (BMS) automatically prevents excessive discharge, charge, voltage and temperature, as well as virtually eliminating misuse

Batteries and chargers with different capacities are available. Your dealer will identify the best combination for your needs. You should also ask your dealer about optional 5-year warranties, subject to annual check-ups, which give extra peace of mind.



Kawasan Industri MM2100, Jl. Selayar, Mekarwangi, Kec. Cikarang Barat, Kabupaten Bekasi, Jawa Barat 17530  
+6285776986689  
mala@satriaselaras.com

info@catliftruck.com | www.catliftruck.com

WESC2090(09/20) ©2020, MLE B.V. All Rights Reserved. CAT, CATERPILLAR, LET'S DO THE WORK, their respective logos, "Caterpillar Yellow", the "Power Edge" and Cat "Modern Hex" trade dress as well as corporate and product identity used herein, are trademarks of Caterpillar and may not be used without permission.

NOTE: Performance specifications may vary depending on standard manufacturing tolerances, vehicle condition, types of tyres, floor or surface conditions, applications, or operating environment. Trucks may be shown with non-standard options. Specific performance requirements and locally available configurations should be discussed with your Cat lift trucks Dealer. Cat Lift Trucks follows a policy of continual product improvement. For this reason, some materials, options and specifications could change without notice.



DOWNLOAD BROCHURE



WATCH VIDEOS



DOWNLOAD OUR APP

