

# Electric powered forklift 1.6 - 2.0 ton

**TRAIGO<sup>48</sup>**

4 wheel



**TOYOTA**

MATERIAL HANDLING



## Electric powered forklift 1.6 - 2.0 t

Truck specifications				8FBMK16T	8FBM16T	8FBM18T	8FBMK20T	8FBM20T	
Identification	1.1	Manufacturer		Toyota	Toyota	Toyota	Toyota	Toyota	
	1.2	Model		8FBMK16T	8FBM16T	8FBM18T	8FBMK20T	8FBM20T	
	1.3	Drive		Electric	Electric	Electric	Electric	Electric	
	1.4	Operator type		Rider seated	Rider seated	Rider seated	Rider seated	Rider seated	
	1.5	Load capacity/rated load	Q	kg	1600	1600	1800	2000	2000
	1.6	Load centre	c	mm	500	500	500	500	500
	1.8	Load distance, centre of drive axle to fork	x	mm	317	317	317	317	317
	1.9	Wheelbase	Y	mm	1453	1561	1561	1453	1561
	Weight	2.1	Service weight		2952	2973	3071	3274	3261
§		Axle load, with load, front/rear		4056/496	4077/496	4368/503	4661/613	4708/553	
2.3		Axle load, without load, front/rear		1500/1452	1586/1387	1573/1498	1480/1794	1609/1652	
Tyres	3.1	Tyre - pneumatic (P), pneumatic shaped cushion (SE), solid rubber (R)		SE	SE	SE	SE	SE	
	3.2	Tyre size, front		18x7-8	18x7-8	18x7-8	200/50-10	200/50-10	
	3.3	Tyre size, rear		16x6-8	16x6-8	16x6-8	16x6-8	16x6-8	
	3.5	Wheels, number front/rear (x = driven wheels)		2x/2	2x/2	2x/2	2x/2	2x/2	
	3.6	Track width, front	b <sub>10</sub>	mm	905	905	905	925	925
	3.7	Track width, rear	b <sub>11</sub>	mm	880	880	880	880	880
	Dimensions	4.1	Tilt of mast/fork carriage forward/backward	$\alpha/\beta$	deg	5/7	5/7	5/7	5/7
4.2		Height, mast lowered	h <sub>1</sub>	mm	2120	2120	2120	2120	2120
4.3		Free lift	h <sub>2</sub>	mm	115	115	115	115	115
4.4		Lift	h <sub>3</sub>	mm	3300	3300	3300	3300	3300
		Lift height	h <sub>23</sub>	mm	3335	3335	3335	3335	3335
4.5		Height, mast extended	h <sub>4</sub>	mm	3870	3870	3870	3870	3870
4.7		Height of overhead guard (cab)	h <sub>6</sub>	mm	2055	2055	2055	2055	2055
4.8		Seat height/stand height	h <sub>7</sub>	mm	1051	1051	1051	1051	1059
4.12		Coupling height	h <sub>10</sub>	mm	427	427	427	427	427
4.19		Overall length	l <sub>1</sub>	mm	3014	3122	3122	3044	3122
4.20		Length to face of forks	l <sub>2</sub>	mm	2014	2122	2122	2044	2122
4.21		Overall width	b <sub>1</sub>	mm	1060	1060	1060	1152	1152
4.22		Fork dimensions	s/e/l	mm	35/100/1000	35/100/1000	35/100/1000	35/120/1000	35/120/1000
4.23		Fork carriage DIN 15 173, class/type A, B			IIA	IIA	IIA	IIA	IIA
4.24		Fork-carriage width	b <sub>3</sub>	mm	920	920	920	920	920
4.31		Ground clearance, with load, below mast	m <sub>1</sub>	mm	80	80	80	90	90
4.32		Ground clearance, centre of wheelbase	m <sub>2</sub>	mm	101	101	101	107	107
4.33		Aisle width for pallets 1000x1200 crossways	A <sub>st</sub>	mm	3327	3438	3438	3357	3438
4.34	Aisle width for pallets 800x1200 lengthways	A <sub>st</sub>	mm	3460	3568	3568	3490	3568	
4.35	Turning radius	W <sub>b</sub>	mm	1707	1811	1811	1737	1811	
4.36	Internal turning radius	b <sub>13</sub>	mm	68	49	49	68	49	
Performance data	5.1	Travel speed, with/without load		km/h	20/20	20/20	20/20	20/20	20/20
	5.2	Lift speed, with/without load		m/s	0,43/0,61	0,43/0,61	0,42/0,61	0,38/0,54	0,38/0,54
	5.3	Lowering speed, with/without load		m/s	0,53/0,55	0,53/0,55	0,53/0,55	0,52/0,50	0,52/0,50
	5.5	Drawbar pull, with/without load		N	5083/5171	4998/5143	4998/5143	4851/5055	4851/5055
	5.6	Max. drawbar pull, with/without load		N	9534/9437	9448/9409	9448/9409	9157/9197	9157/9197
	5.7	Gradeability, with/without load		%	17,3/22,4	15,3/24,2	15,3/24,2	13,4/24,6	13,4/24,6
	5.8	Max. gradeability, with/without load		%	23,6/22,4	21,0/24,2	21,0/24,2	18,3/24,6	18,3/24,6
	5.9	Acceleration time, with/without load		s	4,6/4,2	4,6/4,2	4,7/4,3	4,7/4,3	4,7/4,3
	5.10	Service brake			Hydraulic	Hydraulic	Hydraulic	Hydraulic	Hydraulic
	Electric motor	6.1	Drive motor rating S2 60 min		kW	6x2	6x2	6x2	6x2
6.2		Lift motor rating S3 15%		kW	11,7	11,7	11,7	11,7	11,7
6.3		Battery acc. to DIN 43 531/35/36 A, B, C, no			43 531A	43 531A	43 531A	43 531A	43 531A
6.4		Battery voltage, nominal capacity K <sub>5</sub>		V/Ah	48/550	48/660	48/660	48/550	48/660
6.5		Battery weight		kg	856	1013	1013	856	1013
6.6		Energy consumption acc. to EN16796:2016		kWh/h	4.5	4.5	4.8	5.1	5.1
Other	8.1	Type of drive control			inverter MOSFET	inverter MOSFET	inverter MOSFET	inverter MOSFET	inverter MOSFET
	8.2	Operating pressure for attachments		bar	183	183	183	183	183
	8.3	Oil volume for attachments		l/min	41,3	41,3	41,3	41,3	41,3
	8.4	Sound level at the driver's ear according to EN 12 053		dB(A)	71,5	71,5	71,5	71,5	71,5

All data are based on table configuration. Other configurations may give other values.

Truck performance and dimensions are nominal and subject to tolerances.

Products and specifications are subject to change without notice.

# Mast dimensions and rated capacities

Model		V								FV				FW				FSV					FSW									
8FBMK16T/18T/20T	Lift height	$h_{23}$	3035	3335	3535	3735	4035	4535	5035	3035	3335	3535	3735	3035	3335	3535	3735	4335	4535	4735	5035	5535	6035	4335	4535	4735	5035	5535	6035	6535	7035	7535
	Lift	$h_3$	3000	3300	3500	3700	4000	4500	5000	3000	3300	3500	3700	3000	3300	3500	3700	4300	4500	4700	5000	5500	6000	4300	4500	4700	5000	5500	6000	6500	7000	7500
	Height, mast lowered	$h_1$	1970	2120	2220	2380	2570	2820	3070	1970	2120	2220	2380	2000	2150	2250	2350	1970	2040	2120	2220	2380	2570	1980	2050	2150	2250	2450	2600	2800	3000	3200
	Height, mast extended <sup>1)</sup>	$h_4$	3570	3870	4070	4270	4570	5070	5570	3580	3880	4080	4280	3555	3855	4055	4255	4845	5045	5245	5545	6045	6545	4845	5045	5245	5545	6045	6545	7045	7545	8045
	Height, mast extended <sup>2)</sup>	$h_4$	4260	4560	4760	4960	5260	5760	6260	4260	4560	4760	4960	4260	4560	4760	4960	5560	5760	5960	6260	6760	7260	5560	5760	5960	6260	6760	7260	7760	8260	8760
	Free lift, without load backrest	$h_2$	80	80	80	80	80	80	80	1430	1580	1680	1840	1440	1590	1690	1790	1460	1530	1610	1710	1870	2060	1430	1500	1600	1700	1900	2050	2250	2450	2650
Free lift, with load backrest	$h_2$	80	80	80	80	80	80	80	745	895	995	1155	735	885	985	1085	745	815	895	995	1155	1345	715	785	885	985	1185	1335	1535	1735	1935	

1) Without load backrest.

2) With load backrest, Height of standard load backrest is 1220 mm.

Pneumatic shaped cushion tyre		V								FV				FW				FSV					FSW									
8FBMK16T	Tilt range, forward	deg	5	5	5	5	5	5	5	5	5	5	5	5	5	5	5	5	5	5	5	5	5	5	5	5	5	5	5	5	5	5
	Tilt range, backward	deg	7(5)	7(5)	7(5)	7(5)	7(5)	7(5)	7(5)	7(5)	7(5)	7(5)	7(5)	7(5)	7(5)	7(5)	7(5)	7(5)	7(5)	7(5)	7(5)	7(5)	5	7(5)	7(5)	7(5)	7(5)	7(5)	5	5	5	5
	Load capacity at 500 mm LC	kg	1600	1600	1600	1600	1600	1600	1450	1600	1600	1600	1600	1600	1600	1600	1600	1550	1550	1500	1450	1400	1250	1550	1550	1500	1450	1400	1250	1100	950	800
8FBMK16T	Tilt range, forward	deg	5	5	5	5	5	5	5	5	5	5	5	5	5	5	5	5	5	5	5	5	5	5	5	5	5	5	5	5	5	5
	Tilt range, backward	deg	7(5)	7(5)	7(5)	7(5)	7(5)	7(5)	7(5)	7(5)	7(5)	7(5)	7(5)	7(5)	7(5)	7(5)	7(5)	7(5)	7(5)	7(5)	7(5)	7(5)	5	7(5)	7(5)	7(5)	7(5)	7(5)	5	5	5	5
	Load capacity at 500 mm LC	kg	1600	1600	1600	1600	1600	1600	1600	1600	1600	1600	1600	1600	1600	1600	1600	1600	1600	1600	1550	1450	1200	1600	1600	1600	1550	1450	1200	1000	800	650
8FBMK18T	Tilt range, forward	deg	5	5	5	5	5	5	5	5	5	5	5	5	5	5	5	5	5	5	5	5	5	5	5	5	5	5	5	5	5	5
	Tilt range, backward	deg	7(5)	7(5)	7(5)	7(5)	7(5)	7(5)	7(5)	7(5)	7(5)	7(5)	7(5)	7(5)	7(5)	7(5)	7(5)	7(5)	7(5)	7(5)	7(5)	7(5)	5	7(5)	7(5)	7(5)	7(5)	7(5)	5	5	5	5
	Load capacity at 500 mm LC	kg	1800	1800	1800	1800	1800	1750	1700	1800	1800	1800	1800	1800	1800	1800	1800	1700	1700	1700	1680	1450	1250	1700	1700	1700	1680	1480	1250	1100	850	800
8FBMK20T	Tilt range, forward	deg	5	5	5	5	5	5	5	5	5	5	5	5	5	5	5	5	5	5	5	5	5	5	5	5	5	5	5	5	5	5
	Tilt range, backward	deg	7(5)	7(5)	7(5)	7(5)	7(5)	7(5)	7(5)	7(5)	7(5)	7(5)	7(5)	7(5)	7(5)	7(5)	7(5)	7(5)	7(5)	7(5)	7(5)	7(5)	5	7(5)	7(5)	7(5)	7(5)	7(5)	5	5	5	5
	Load capacity at 500 mm LC	kg	2000	2000	2000	2000	2000	2000	1950	2000	2000	2000	2000	2000	2000	2000	2000	1950	1950	1950	1800	1650	1550	1950	1950	1950	1900	1850	1600	1200	900	800
8FBMK20T	Tilt range, forward	deg	5	5	5	5	5	5	5	5	5	5	5	5	5	5	5	5	5	5	5	5	5	5	5	5	5	5	5	5	5	5
	Tilt range, backward	deg	7(5)	7(5)	7(5)	7(5)	7(5)	7(5)	7(5)	7(5)	7(5)	7(5)	7(5)	7(5)	7(5)	7(5)	7(5)	7(5)	7(5)	7(5)	7(5)	7(5)	5	7(5)	7(5)	7(5)	7(5)	7(5)	5	5	5	5
	Load capacity at 500 mm LC	kg	2000	2000	2000	2000	2000	1900	2000	2000	2000	2000	2000	2000	2000	2000	1950	1950	1900	1800	1650	1550	1950	1950	1900	1850	1800	1650	1350	1050	950	

Data in ( ) are for when "Cabin Series" is selected (minimum front windshield).

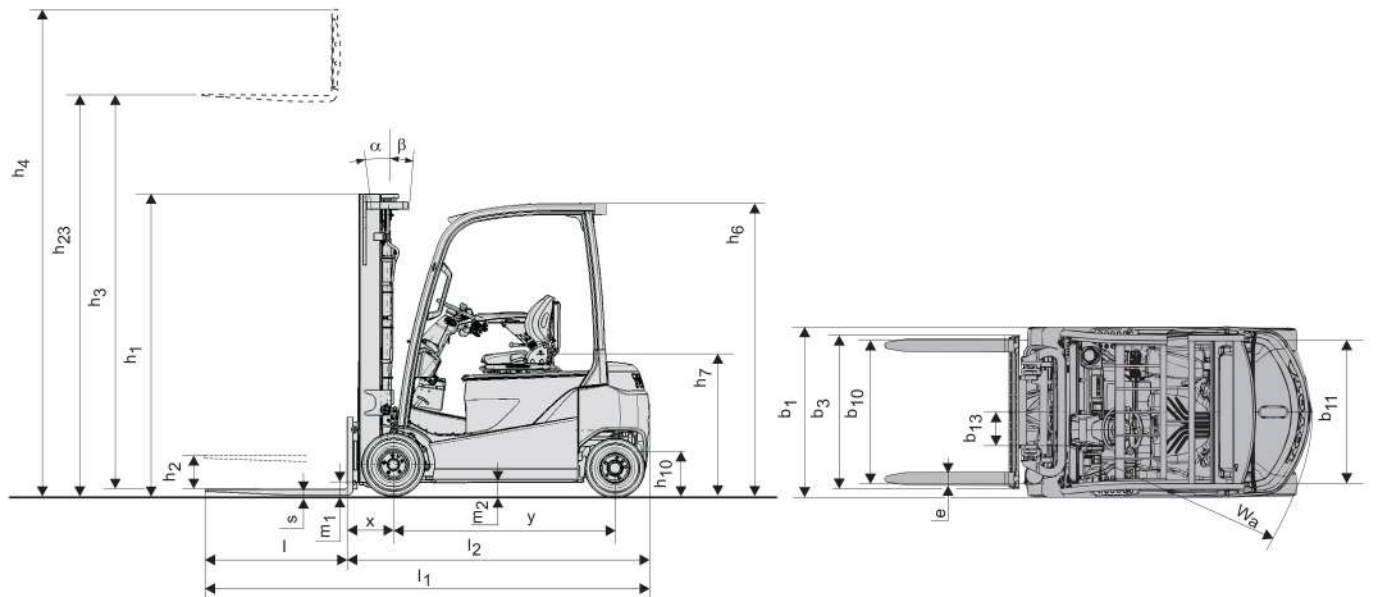

## Standard equipment:

- Toyota SAS (System of Active Stability)
- Toyota AC<sup>2</sup> power system
- Operator presence sensing system (OPS)
- Toyota ORS seat (Operator Restraint System)
- Seat mounted hydraulic minilevers
- Direction switch on armrest
- Wide visible mast (V3300 mm)
- Long forks (length:1000 mm)
- Long forkbar (length: 920 mm)
- 3 way valves (A400)
- Automatic parking brake
- Wet disc brakes
- Wide brake pedal
- Pneumatic shaped cushion tyres
- Hydraulic power steering
- Digital Multifunction display with wheel indicator
- Adjustable tilt steering column with memory function



TMHE-Toyota Material Handling Europe — 745556-040, version 8, 2020-04-22

**TOYOTA**

MATERIAL HANDLING